

## Webnet micro

**Rope construction** 6 × 7 + WC, minimum breaking load 1.37 kN

**로프 구조** 6 × 7 + WC, 최소 파단 하중 1.37 kN

Swaged **sleeve dimensions** 5.5 × 6 × 2.8 mm

압착된 **슬리브 사이즈** 5.5 × 6 × 2.8 mm

AISI 316 material group

No.	Rope	Mesh aperture	Weight	Rope length	Number of sleeves	Light transmission
	Ø mm	W x H mm	kg/m <sup>2</sup>	m/m <sup>2</sup>	per m <sup>2</sup>	%
20261-0150-025	1.5	25 x 45.46	1.84	88	1822	83.8
20261-0150-030	1.5	30 x 60.73	1.28	73	1105	87.2
20261-0150-035	1.5	35 x 67.98	1.20	62	855	89.3
20261-0150-040	1.5	40 x 75.40	0.85	55	663	90.7
20261-0150-050	1.5	50 x 91.39	0.64	44	451	92.7
20261-0150-060	1.5	60 x 107.78	0.50	38	315	93.8
20261-0150-070	1.5	70 x 124.78	0.47	32	232	94.8
20261-0150-080	1.5	80 x 141.45	0.34	29	189	95.3
20261-0150-100	1.5	100 x 175.34	0.30	22	126	96.5
20261-0150-120	1.5	120 x 210.36	0.24	18	85	97.2
20261-0150-140	1.5	140 x 244.98	0.20	16	60	97.5
20261-0150-160	1.5	160 x 280.10	0.17	14	46	97.8
20261-0150-180	1.5	180 x 314.33	0.14	14	39	97.8
20261-0150-200	1.5	200 x 348.51	0.13	11	33	98.3
20261-0150-250	1.5	250 x 435.60	0.12	9	22	98.6
20261-0150-400	1.5	400 x 694.10	0.07	6	12	99.1

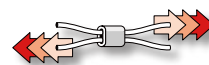
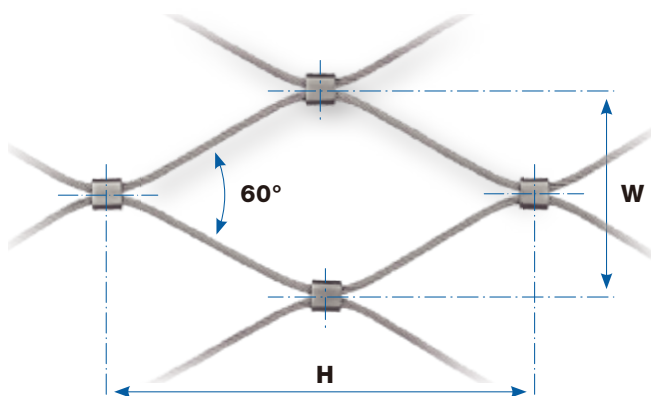

**L = 0.1 kN**

길이 방향 노드 강도

Longitudinal node strength

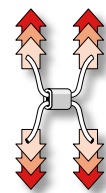

**Q = 2 kN**

횡방향 노드 강도  
(스웨이지의 파단 하중)  
Transversal node strength  
(breaking load of swage)

## Webnet micro

**Rope construction** 6 × 7 + WC, minimum breaking load 2.4 kN

**로프 구조** 6 × 7 + WC, 최소 파단 하중 2.4 kN

Swaged **sleeve dimensions** 7.5 × 7.5 × 4 mm

압착된 **슬리브 사이즈** 7.5 × 7.5 × 4 mm

AISI 316 material group

No.	Rope		Mesh aperture W x H mm	Weight kg/m <sup>2</sup>	Rope length m/m <sup>2</sup>	Number of sleeves per m <sup>2</sup>	Light transmission %
	Ø mm						
20261-0200-040	2		40 x 74.93	1.54	55	663	89.00
20261-0200-050	2		50 x 91.11	1.16	44	451	91.20
20261-0200-060	2		60 x 107.54	0.92	38	315	92.40
20261-0200-070	2		70 x 124.10	0.74	32	232	93.60
20261-0200-080	2		80 x 141.03	0.65	29	189	94.20
20261-0200-100	2		100 x 175.16	0.48	22	126	95.60
20261-0200-120	2		120 x 209.78	0.37	18	85	96.40
20261-0200-140	2		140 x 244.11	0.32	16	60	96.80
20261-0200-160	2		160 x 278.29	0.27	14	46	97.20
20261-0200-180	2		180 x 313.20	0.26	14	39	97.40
20261-0200-200	2		200 x 348.40	0.21	11	33	97.80
20261-0200-250	2		250 x 435.20	0.17	9	22	98.20
20261-0200-400	2		400 x 693.00	0.11	6	12	98.80

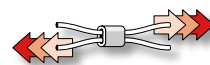
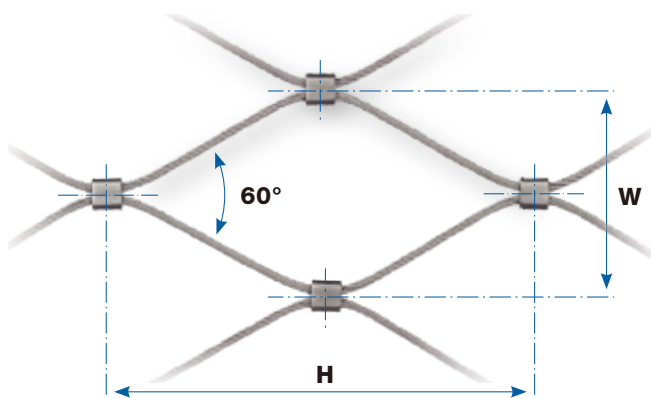

**L = 0.3 kN**

길이 방향 노드 강도

Longitudinal node strength

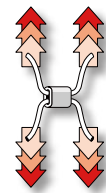

**Q = 2.6 kN**

횡방향 노드 강도  
(스웨이징 파단 하중)

Transversal node strength  
(breaking load of swage)